

Brass Ball Valves

Two-Piece Body • Full Port • Blowout-Proof Stem • PTFE Seats
• British Parallel Pipe Threads

580 PSI/40 Bar Non-Shock Cold Working Pressure

UL LISTED† • FM APPROVED‡

MATERIAL LIST

PART	SPECIFICATION
1. Body	Forged Brass* CU > 57%
2. End Cap	Forged Brass* CU > 57%
3. Ball Seat	PTFE
4. Ball	Brass, Chrome Plated
5. Stem	Brass
7. Stem Packing	PTFE
8. Packing Nut	Brass
9. Lever Handle	Steel, Plated
11. Handle Nut	Steel, Plated

Note: * For Material Certification, contact NIBCO Technical Services.



T-FP-40-BSPP

Threaded

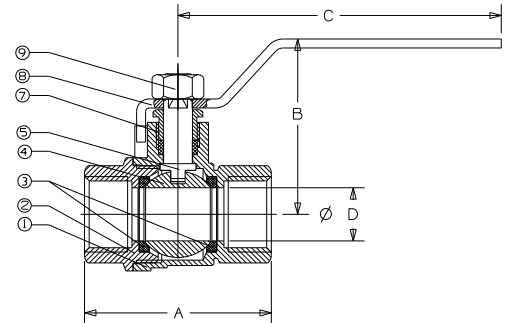

T-FP-40-BSPP
BSPP

DIMENSIONS—WEIGHTS—QUANTITIES

Size		A		B		C		Port D		Lbs.	Kg.	Ctn. Qty.
In.	mm.	In.	mm.	In.	mm.	In.	mm.	In.	mm.			
1/2	15	2.27	52	1.92	49	3.54	90	0.59	15	0.47	0.21	18
3/4	20	2.61	60	2.09	53	3.78	96	0.75	19	0.68	0.31	12
1	25	3.07	70	2.56	65	4.53	115	0.98	25	1.11	0.50	6
1 1/4	32	3.70	84	2.95	75	4.53	115	1.26	32	1.69	0.77	4
1 1/2	40	4.04	93	3.35	85	5.51	140	1.57	40	2.55	1.16	2
2	50	4.81	106	3.68	93	5.51	140	1.97	50	3.81	1.73	2

† UL Subject 258

‡ FM Approved at 24 Bar (350 psi) WWP Service

